



DBK5™

4-Channel Current-Output Card



Compatibility: ✓ DaqBook ✓ DaqLab ✓ DaqScan ✓ DaqBoard/2000 Series

Features

- Provides four isolated 4 to 20 mA current outputs
- Complies with current loop resistances of up to 1950 Ohms
- Compatible with 12V to 45V current loop supplies
- Features predictable power-on and fault states
- Provides 12-bit resolution

The DBK5™ current-output card provides IOtech's data acquisition systems with the ability to control four isolated 4 to 20 mA current loops. The DBK5 acts as a current loop transmitter by modulating current from an external source. The DBK5 can be programmed with a static value whenever the data acquisition system is not transferring A/D data. As many as 64 DBK5s can be used in one system to obtain up to 256 outputs.



The DBK5 current-output card controls four isolated 4 to 20 mA current loops

Architecture. Each of the DBK5's channels contains a 12-bit D/A converter to set the loop current. All channels are optically isolated from the data acquisition system and from one another by 500V. A regulator allows the isolated circuitry to draw power from the external loop power supply. The card's current buffers provide per-channel trim adjustments via potentiometers. (See diagram at right for DBK5 architecture.)

Applications. The DBK5 is ideal for applications that require test and calibration of current loop receivers, including actuators or final-control elements such as pneumatic valves and hydraulic cylinders. It is also useful for research applications that require control of such actuators.

Current Loop. The DBK5 is compatible with regulated or unregulated loop supplies of 12 to 45 VDC. It also provides compliance with loop resistances of up to 1950 Ohms, depending on the source magnitude.

DBK5 Current-Output Card Block Diagram

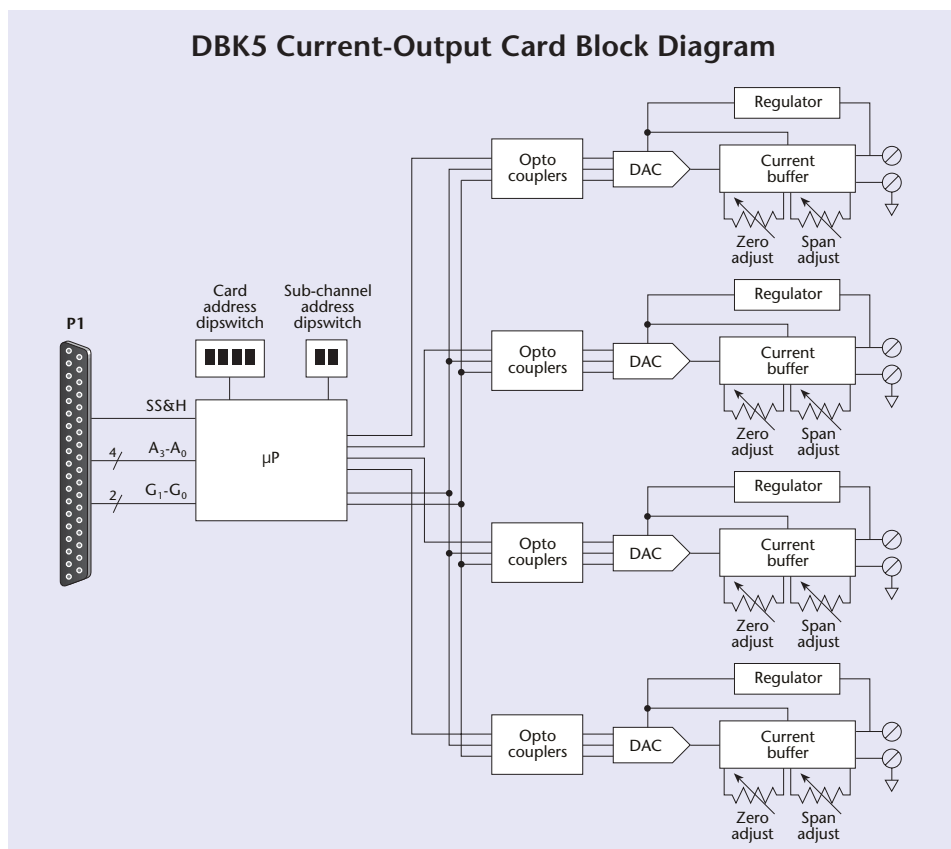



DBK5™

Specifications & Ordering Information

A Typical DBK5 Application

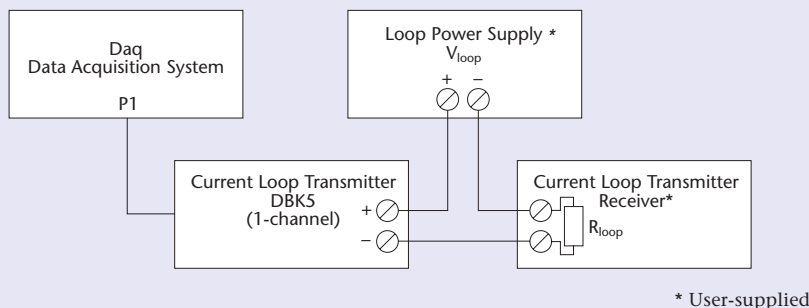

Isolation. The DBK5 provides 500V channel-to-channel and 500V channel-to-system optical isolation for system protection.

Current Loop-Powered Outputs. Since the isolated outputs of the DBK5 are loop powered, the card maintains control of the loop current even when the data acquisition system is powered down. When loop power is first applied, the DBK5's outputs assume their 4 mA default state. If at any time the data acquisition system's power is lost or communication with the data acquisition system fails, the DBK5's outputs retain their last set values.

Specifications

Connectors: DB37 male, mates with P1**, screw terminals for signal outputs

Accuracy/Linearity: 0.1% full scale

Resolution: 4 μ A/LSB, monotonic

Hysteresis: 0.02% full scale

Regulation: 0.05% full scale

Isolation Voltage

Channel-to-Channel: 500V

Channel-to-System: 500V

Voltage Range: $V_{loop} = 12$ to 45V

Compliance: $R_{loop} = (V_{loop} - 6) / 0.020$

Example Voltage

@ $V_{exc} = 35V$ MDR† 1450 Ohms

@ $V_{exc} = 25V$ 950 Ohms

@ $V_{exc} = 15V$ 450 Ohms

Power Consumption: 135 mW

Ordering Information

Description
4-channel current-output card

Part No.
DBK5

Cables

For use with DBK10, use CA-37-x ribbon cable, or contact factory of additional cabling options

For use with DBK60 or LogBook360, no cable is required (except from DBK60 or LogBook/360 to the A/D mainframe)

For use with no enclosure, use CA-37-x where x is the number of DBK devices attached

For use with DaqLab series (internal slots), use CA-255-2T with one board, or CA-37-2 for use with two DBK cards (or contact factory for additional cabling options)

For complete information on accessories and cables, visit www.iotech.com/acc

Related Products

DaqBook	p. 89
DaqLab	p. 103
DaqScan	p. 108
DBK10	p. 126
DBK41	p. 146
DBK60	p. 160
DaqBoard/2000 Series	p. 192

** Attachment to the DaqBoard/2000 series requires a DBK200, DBK201, DBK202, DBK203, DBK205, or DBK209 adapter

† MDR (maximum drive resistance)